

# DLT-V7210K Data Sheet



## Rugged, X86-based Vehicle Mount Terminal with integrated hardware keyboard

- 10.1" wide screen Color-TFT for various host applications and user interaction requirements
- Break and abrasion resistant PCT touchscreen
- Wide temperature range to handle cold storage and hot, humid environments
- Rugged IP65 and 5M3 shock and vibration certifications for the complete system
- Integrated uninterruptible power supply (UPS), optional
- Integrated hardware keyboard which facilitates typing

The DLT-V7210 with integrated hardware keyboard is a rugged vehicle mount terminal designed for maximum uptime and logistics - meeting a wide temperature range from hot and humid to cold freezer environments - whether dry or intense humidity. The integrated Advantech-DLoG low profile antenna solution combines excellent high transmission quality in a smaller, driver-friendly size. The integrated, user-friendly hardware keyboard available in different country versions enables efficient data input. An easy to use 10.1" wide touch screen reduces input failures by operator.

## Specification

System	CPU Mass storage memory	Intel® ATOM™ E3845 Quad Core 1.91 GHz with 4 GB RAM 8 GB CFast or more
Dimensions/Weight		Width x height x depth in mm: 297 x 239 x 81 (11.7" x 9.4" x 3.2") 3.7 kg (without battery pack/accessories) (8.2 lbs.)
Housing		Completely sealed, fanless design, coated aluminium
Display		Color-TFT 10.1" wide screen WXGA 1280x800, 500 cd/m <sup>2</sup>
Touch screen		Sunlight readable projective capacitive touch screen (PCT), multi-touch Touch sensitivity via Config Tool adjustable
Front keys/Keyboard	Front Keys	12 side keys, thereof 6 freeprogrammable
	Keyboard	Full 55-key keyboard with number pad Keyboard available in different country versions: QWERTY, QWERTZ, AZERTY Keyboard illuminated and field replaceable; silicon mat can be exchanged
Software	Operating systems	MS-Windows® 10 IoT Enterprise, MS-Windows® 7 Professional MS-Windows® Embedded 8.1 Industry Pro, WES7, WE8S Linux based on Debian, IGEL Linux
	Emulations (third-party)	VT100, VT220, IBM 5250, TN 3270, Citrix Client®, Freefloat Access One
Communication	Wi-Fi	Wi-Fi IEEE 802.11 a/b/g/n, optional
	LAN	Ethernet 10/100/1000 MBit/s
	WPAN	Bluetooth, optional
Interfaces	Serial	2 x RS-232; COM1 optionally switchable 5 VDC / RI
	USB	4 x USB 2.0 (HI-SPEED™), bootable; 1 x Service USB 3.0 (SUPER-SPEED™)
	RSMA	1 x RSMA for external antenna (Wi-Fi), optional
Audio/Voice		Speaker integrated
Power supply (internal)		12/24/48 VDC nominal voltages
		Automatic switch-on/switch-off function via vehicle ignition UPS, optional (typically 20 min); battery-life time may vary depending on use case
Environmental	IP protection class	IP65 for the complete system
	Operating temperature	-30 to +50 °C (-22 to +122 °F)
	Relative humidity	10 to 90% @ 40 °C, non condensing
	Shock/Vibration	Class 5M3 according to EN 60721-3-5, US Highway Truck as MIL-STD 810F
Approvals	Shock resistance touchscreen	IK 08
		EU, USA: CE Immunity Class A, Emission Class B / FCC Class B
		Taiwan: BSMI / NCC Japan: MIC / VCCI China: CCC / SRRC

# DLT-V7210K

## Dimensions (in mm)

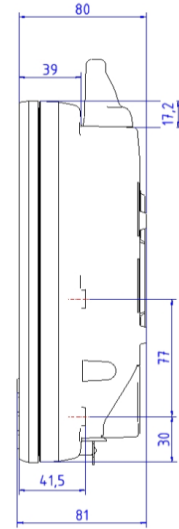
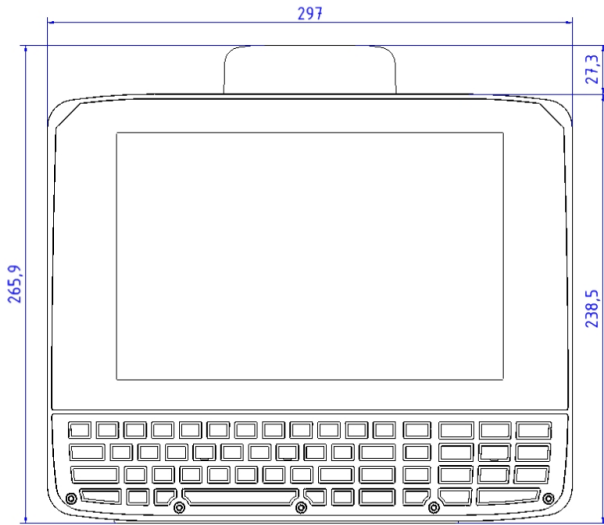

## Connectors

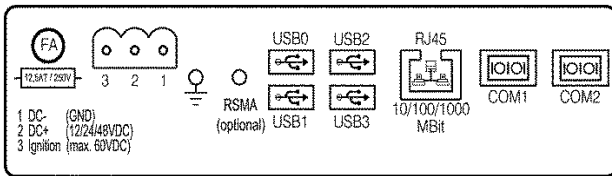

## Mounting Variants (Selection)

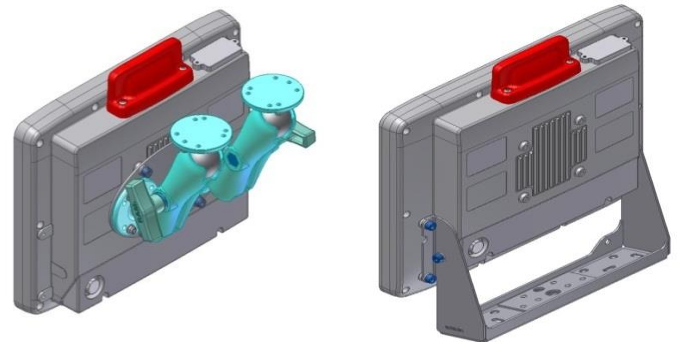

## Advantech-DLoG Partner Contact

## Accessories

- Scanners with mountings
- Keyboards with mountings
- Stylus with mountings
- Terminal mountings (wide range of mounting brackets, RAM solutions)
- USB Recovery Stick